

AlGaAs/AlGaAs Infrared Chip ---TK0712IRP

1. Scope

- The specification applies to AlGaAs infrared chips.
- Type : TK0712IRP.

2. Structure

- AlGaAs/AlGaAs infrared chip.
- P/N mesa type.
- Electrode P (anode) side : Aluminum or Gold.
- Electrode N (cathode) side : Gold alloy.

3. Size

- Chip Size : $300\mu\text{m} \times 300\mu\text{m}$
- Chip height : $175\mu\text{m} \pm 35\mu\text{m}$
- Pattern drawing : per fig. 1

4. Electro-Optical Characteristics

($T_a = +25^\circ\text{C}$)

Parameter	Symbol	Condition	Min.	Typ.	Max.	Unit
Forward Voltage	V_F	$I_F = 20\text{mA}$		1.45	1.55	V
Forward Voltage	V_F	$I_F = 50\text{mA}$		1.55	1.75	
Reverse Voltage	V_R	$I_R = 10\mu\text{A}$	5			V
Radiant Power	P_O	$I_F = 20\text{mA}$	3.2			mw
Radiant Power	P_O	$I_F = 50\text{mA}$	7.5			
Peak Wavelength	λ_p	$I_F = 20\text{mA}$		850		nm
Spectrum Width of Half Value	$\Delta\lambda$	$I_F = 20\text{mA}$		50		nm
Optical Rise Time	T_R	$I_F = 20\text{mA}$		25		ns
Optical Fall Time	T_F	$I_F = 20\text{mA}$		13		ns

5. Application

- Wireless earphones, Wireless mouse, CCD of light.

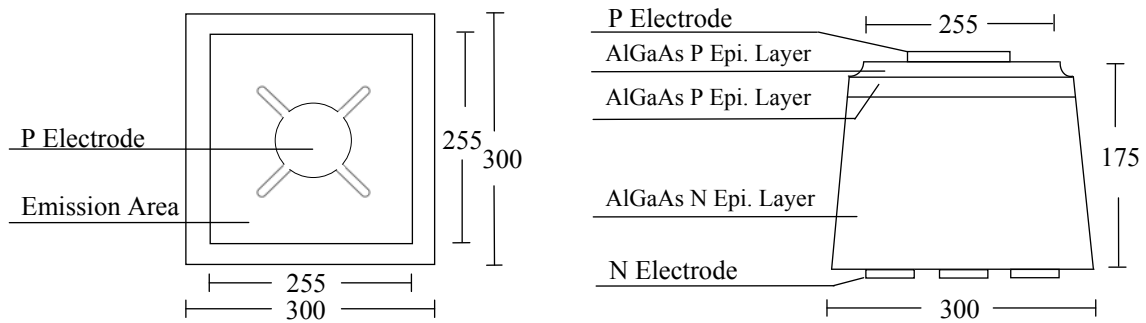

Unit : μm

fig. 1

2015.Mar



TYNTEK Head Office
 TYNTEK Chunan Branch
<http://www.tyntek.com.tw>

Tel : 886-3-5781616
 Tel : 886-37-582997

Fax : 886-3-5780545
 Fax : 886-37-582908

E-mail : service@serv.tyntek.com.tw

AlGaAs/AlGaAs Infrared Chip ---TK0712IRP

Electro-Optical Characteristics Curve

