

GaAsP/GaP Orange Chip ---TK0207HOD



1. Scope

- The specification applies to GaAsP LED chips for BROADCOM AVAGO Technologies.
- Type : TK0207HOD.

2. Structure

- GaAsP/GaP orange LED chip.
- P/N mesa type.
- Electrode P (anode) side : Aluminum or Gold.
- Electrode N (cathode) side : Gold alloy.

Temporary

3. Size

- Chip size : 175 μ m \times 175 μ m (center to center) 150 μ m \times 150 μ m \pm 25 μ m (Bottom).
- Chip height : 200 μ m \pm 30 μ m
- Pad size : 105 μ m \pm 12.5 μ m
- Pattern drawing : per fig. 1

4. Electro-Optical Characteristics

(Ta = +25 $^{\circ}$ C)

Parameter	Symbol	Condition	Min.	Typ.	Max.	Unit
Forward Voltage	V _F	I _F =20 mA		2.15	2.50	V
Reverse Current	I _R	V _R =5 V			10	μ A
Luminous Intensity	I _V	I _F =20 mA				mcd
Wavelength	λ_p / λ_d	I _F =20 mA		640/628		nm
Spectrum Width of Half Value	$\Delta \lambda$	I _F =20 mA		35		nm

※ For AVAGO series, I_v by AVAGO unit.

※ BIN table

Normal type : I_v(120~270 ucd)

P side rough surface : I_v(210~360 ucd)

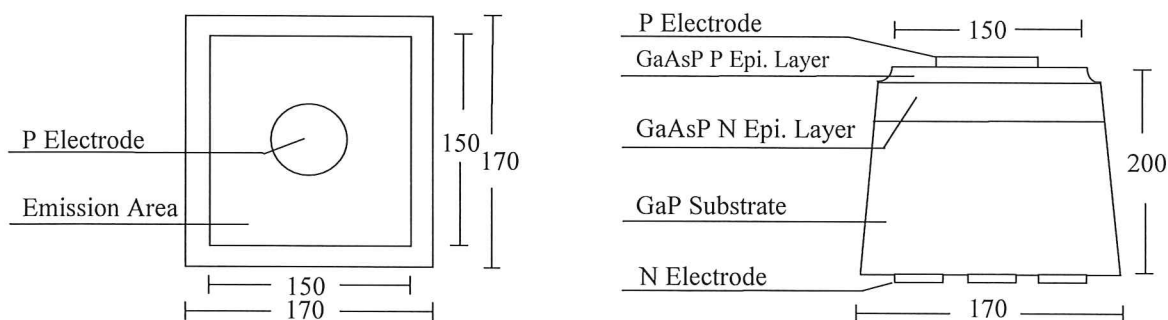

Unit : μ m

fig. 1

2017.Jun

