

# AlGaAs/AlGaAs Infrared Chip ---TK0116IRP

## 1. Scope

- The specification applies to AlGaAs infrared chips.
- Type : TK0116IRP.

## 2. Structure

- AlGaAs/AlGaAs infrared chip.
- P/N mesa type.
- Electrode P (anode) side : Aluminum or Gold.
- Electrode N (cathode) side : Gold alloy.

## 3. Size

- Chip size :  $400\mu\text{m} \times 400\mu\text{m}$
- Chip height :  $175\mu\text{m} \pm 35\mu\text{m}$
- Pattern drawing : per fig. 1

## 4. Electro-Optical Characteristics

( $T_a = +25^\circ\text{C}$ )

Parameter	Symbol	Condition	Min.	Typ.	Max.	Unit
Forward Voltage	$V_F$	$I_F = 20\text{mA}$		1.40	1.55	V
Reverse Voltage	$V_R$	$I_R = 10\mu\text{A}$	5			V
Radiant Power	$P_O$	$I_F = 20\text{mA}$	4.0			mw
Peak Wavelength	$\lambda_p$	$I_F = 20\text{mA}$		850		nm
Spectrum Width of Half Value	$\Delta\lambda$	$I_F = 20\text{mA}$		50		nm
Optical Rise Time	$T_R$	$I_F = 20\text{mA}$		25		ns
Optical Fall Time	$T_F$	$I_F = 20\text{mA}$		13		ns

## 5. Application

- Wireless earphones, Wireless mouse, CCD of light.

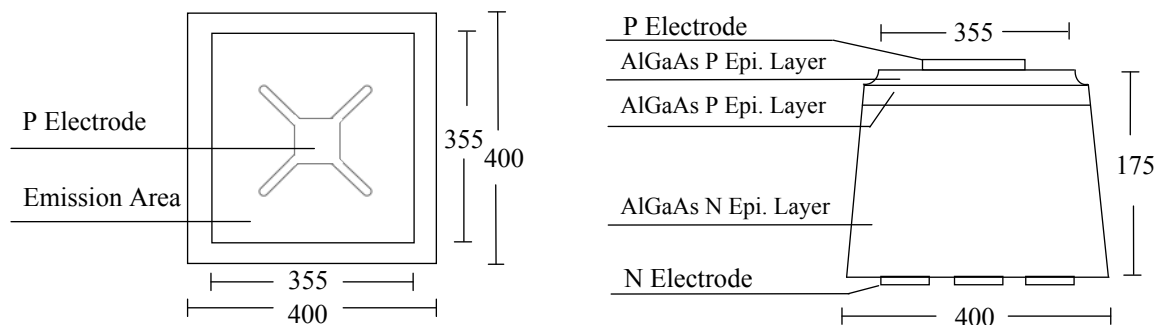

Unit :  $\mu\text{m}$

fig. 1

2015.Mar



TYNTEK Head Office  
 TYNTEK Chunan Branch  
<http://www.tyntek.com.tw>

Tel : 886-3-5781616

Tel : 886-37-582997

E-mail : [service@serv.tyntek.com.tw](mailto:service@serv.tyntek.com.tw)

Fax : 886-3-5780545

Fax : 886-37-582908

# AlGaAs/AlGaAs Infrared Chip ---TK0116IRP

## Electro-Optical Characteristics Curve

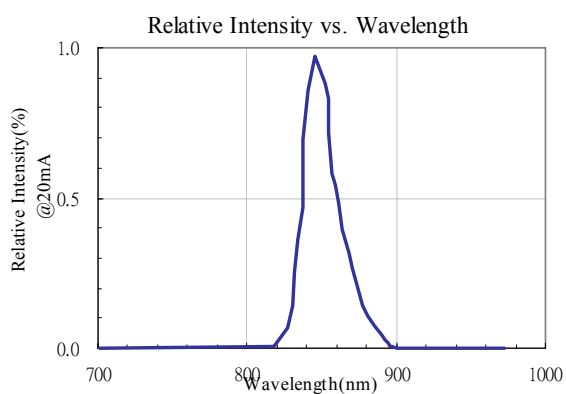
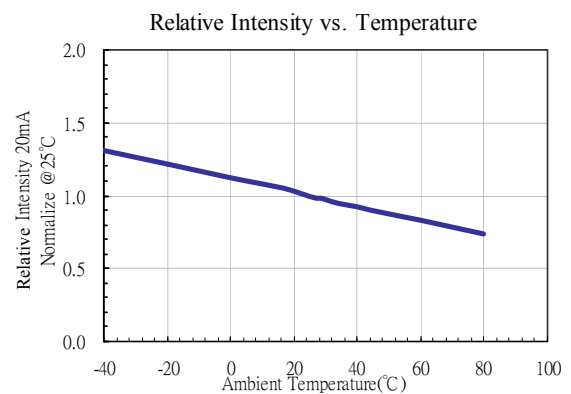
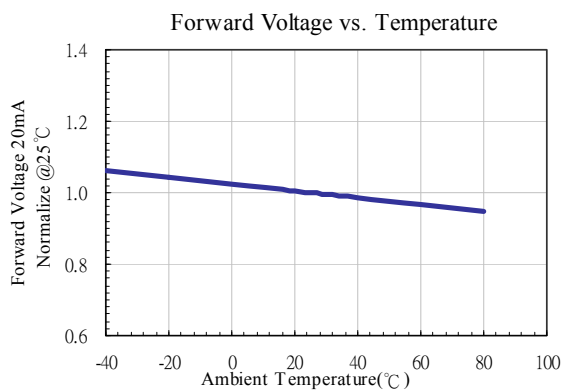
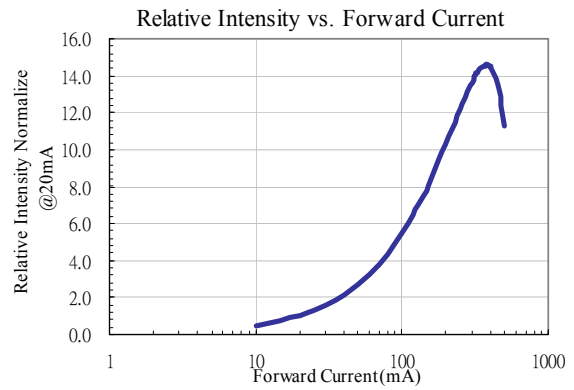
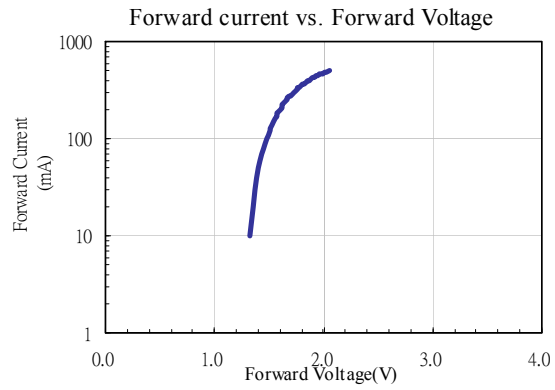

TYNTEK Head Office  
 TYNTEK Chunan Branch  
<http://www.tyntek.com.tw>

Tel : 886-3-5781616  
Tel : 886-37-582997

Fax : 886-3-5780545  
Fax : 886-37-582908

E-mail : [service@serv.tyntek.com.tw](mailto:service@serv.tyntek.com.tw)