

GaP/GaP Pure Green Chip ---TK0111PGN

1. Scope

- The specification applies to GaP LED chips.
- Type : TK0111PGN.

2. Structure

- GaP/GaP pure green LED chip.
- P/N mesa type.
- Electrode P (anode) side : Aluminum or Gold.
- Electrode N (cathode) side : Gold alloy.

3. Size

- Chip size : $275\mu\text{m} \times 275\mu\text{m}$
- Chip height : $260\mu\text{m} \pm 30\mu\text{m}$
- Pattern drawing : per fig. 1

4. Electro-Optical Characteristics

($T_a = +25\text{ }^\circ\text{C}$)

Parameter	Symbol	Condition	Min.	Typ.	Max.	Unit
Forward Voltage	V_F	$I_F = 20\text{mA}$		2.25	2.40	V
Reverse Current	I_R	$V_R = 5\text{V}$			10	μA
Luminous Intensity	I_V	$I_F = 20\text{mA}$	1.0	2.8		mcd
Wavelength	λ_p / λ_d	$I_F = 20\text{mA}$		555/560		nm
Spectrum Width of Half Value	$\Delta \lambda$	$I_F = 20\text{mA}$		25		nm

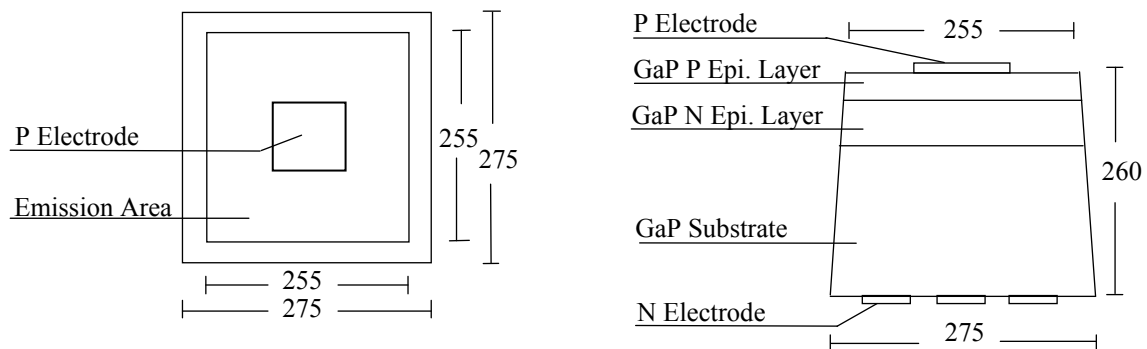

Unit : μm

fig. 1

2012.May



GaP/GaP Pure Green Chip ---TK011PGN

Electro-Optical Characteristics Curve

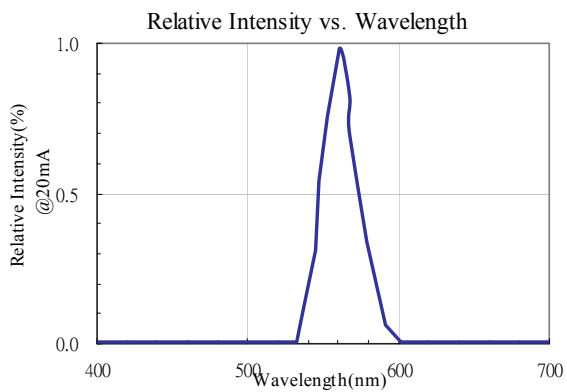
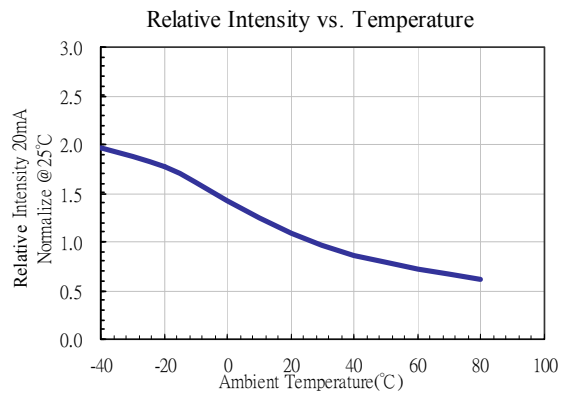
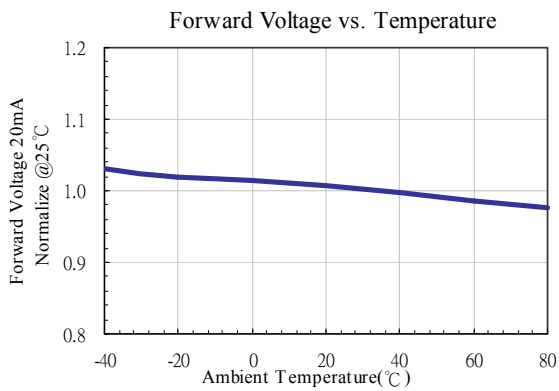
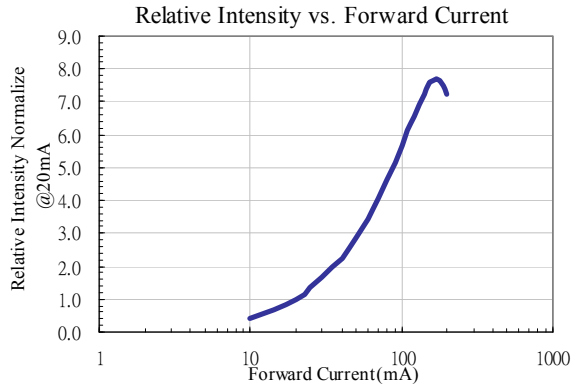
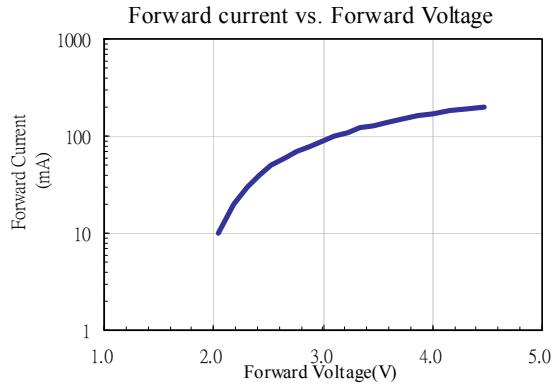

TYNTEK Head Office
 TYNTEK Chunan Branch
<http://www.tyntek.com.tw>

Tel : 886-3-5781616

Tel : 886-37-582997

E-mail : service@serv.tyntek.com.tw

Fax : 886-3-5780545

Fax : 886-37-582908