

GaAsP/GaP Soft Orange Chip ---TK0109SON

1. Scope

- The specification applies to GaAsP LED chips.
- Type : TK0109SON.

2. Structure

- GaAsP/GaP soft orange LED chip.
- P/N mesa type.
- Electrode P (anode) side : Aluminum or Gold.
- Electrode N (cathode) side : Gold alloy.

3. Size

- Chip size : $225\mu\text{m} \times 225\mu\text{m}$
- Chip height : $210\mu\text{m} \pm 30\mu\text{m}$
- Pattern drawing : per fig. 1

4. Electro-Optical Characteristics

($T_a = +25\text{ }^\circ\text{C}$)

Parameter	Symbol	Condition	Min.	Typ.	Max.	Unit
Forward Voltage	V_F	$I_F = 20\text{mA}$		2.15	2.50	V
Reverse Current	I_R	$V_R = 5\text{V}$			10	μA
Luminous Intensity	I_V	$I_F = 20\text{mA}$	5.0	※		mcd
Wavelength	λ_p / λ_d	$I_F = 20\text{mA}$		620/607		nm
Spectrum Width of Half Value	$\Delta \lambda$	$I_F = 20\text{mA}$		35		nm

- ※
- Rank C : $6.0 \leq \text{avg.} < 8.0$ mcd
 - Rank D : $8.0 \leq \text{avg.} < 10.0$ mcd
 - Rank E : $\text{avg.} \geq 10.0$ mcd

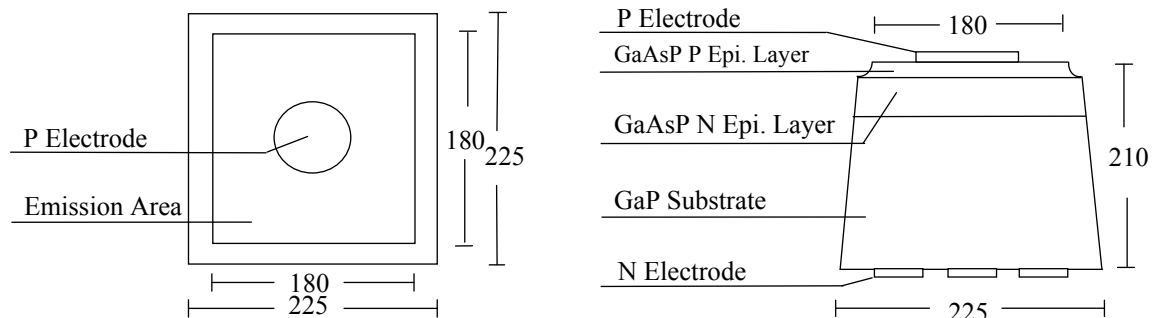

Unit : μm

fig. 1

2012.May



GaAsP/GaP Soft Orange Chip ---TK0109SON

Electro-Optical Characteristics Curve

